

COLOR THEORY: THE COLOR WHEEL

•Center/Neutral colors

White

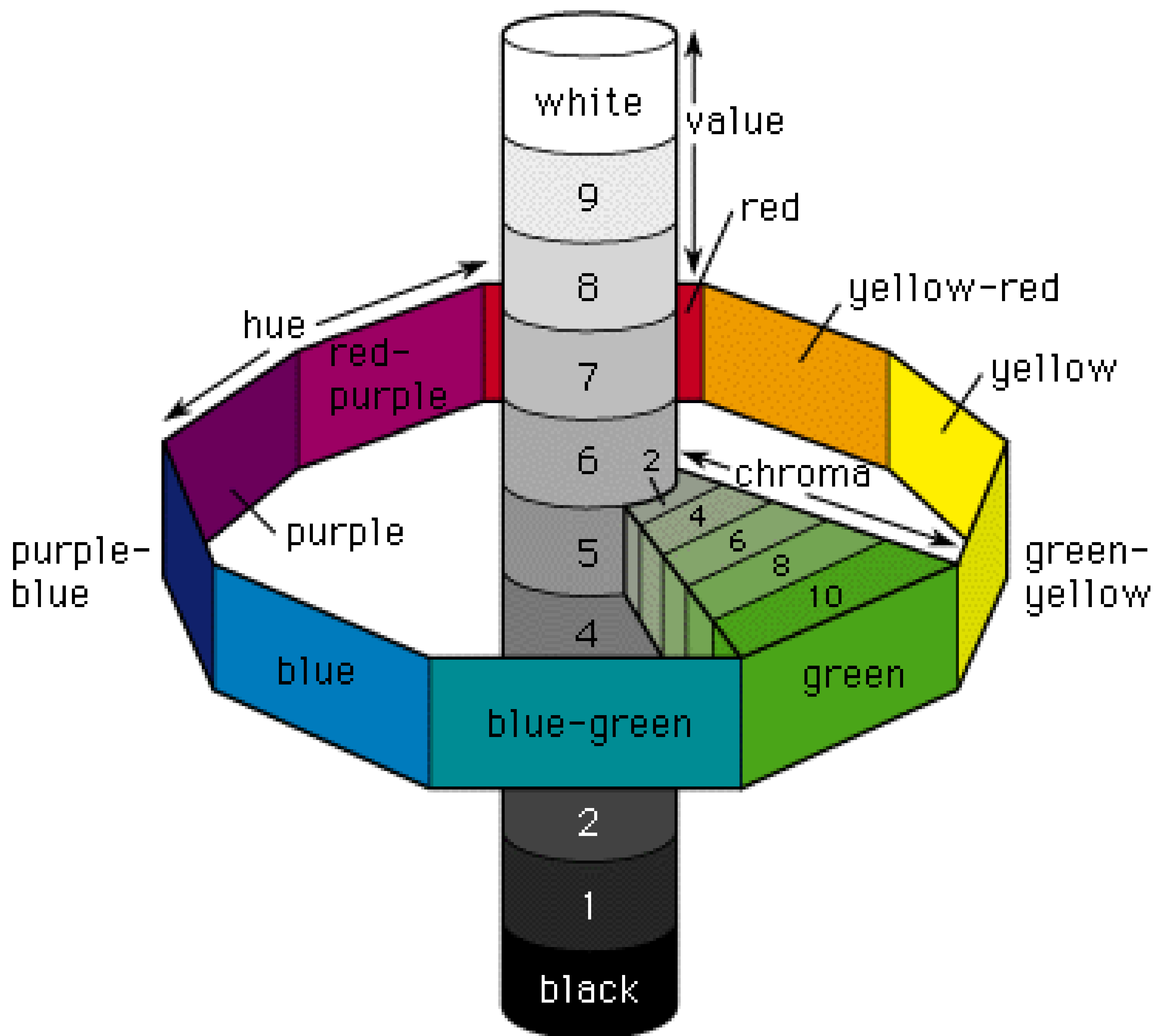

©1994 Encyclopaedia Britannica, Inc.

Black

Observation and Assessment of Sprayout

Face description technique

1. 3M Sun Gun should be at a 65° angle to the car and close to the technicians left ear. (Fig. 1)
2. The technicians eyes should be at a 90° angle perpendicular to the car and approximately 12" - 18" away. (Fig. 1)
3. When viewing the variant or spray out swatch, the technician should be at eye level focusing primarily on the center and bottom of the panel. (Fig. 2)

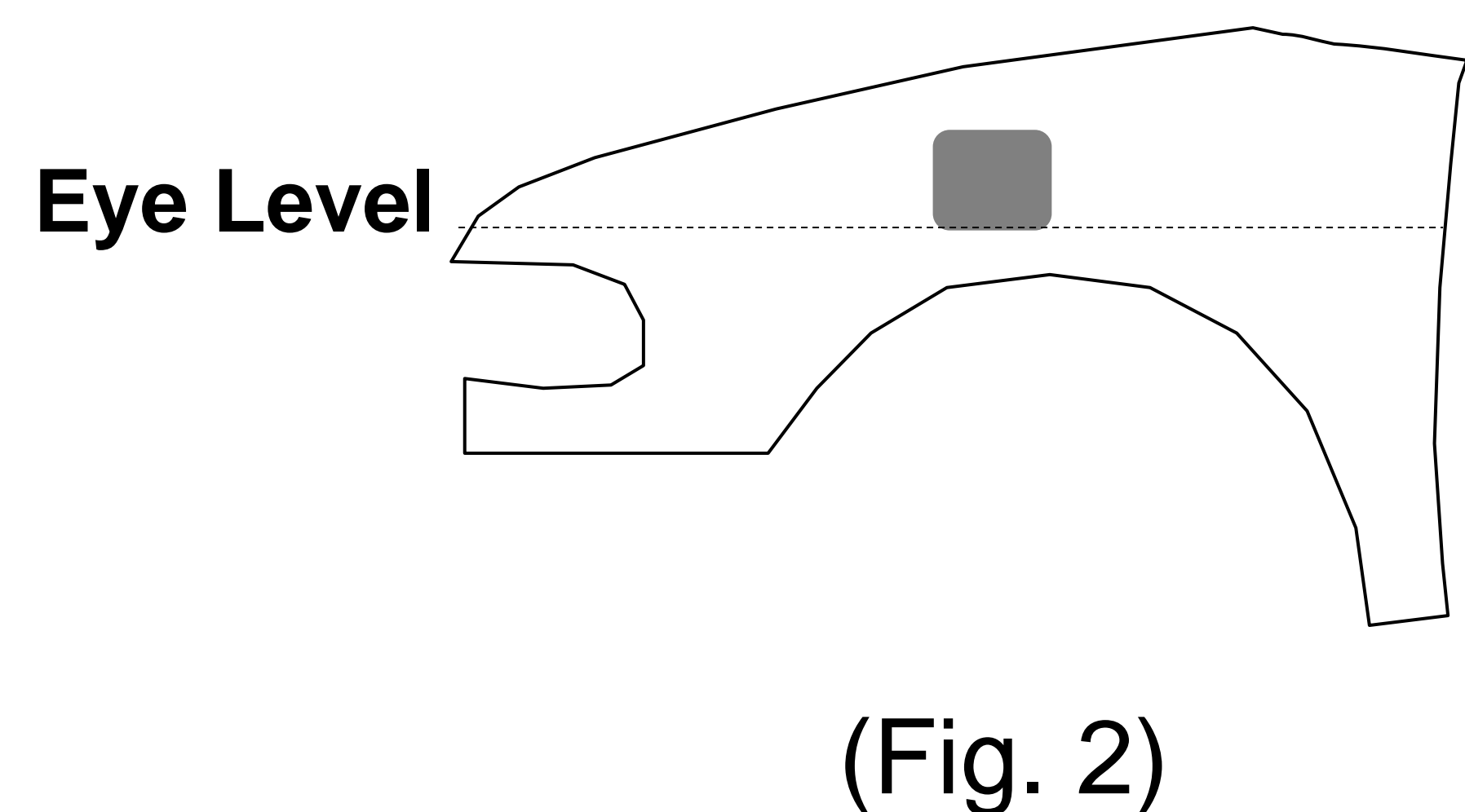
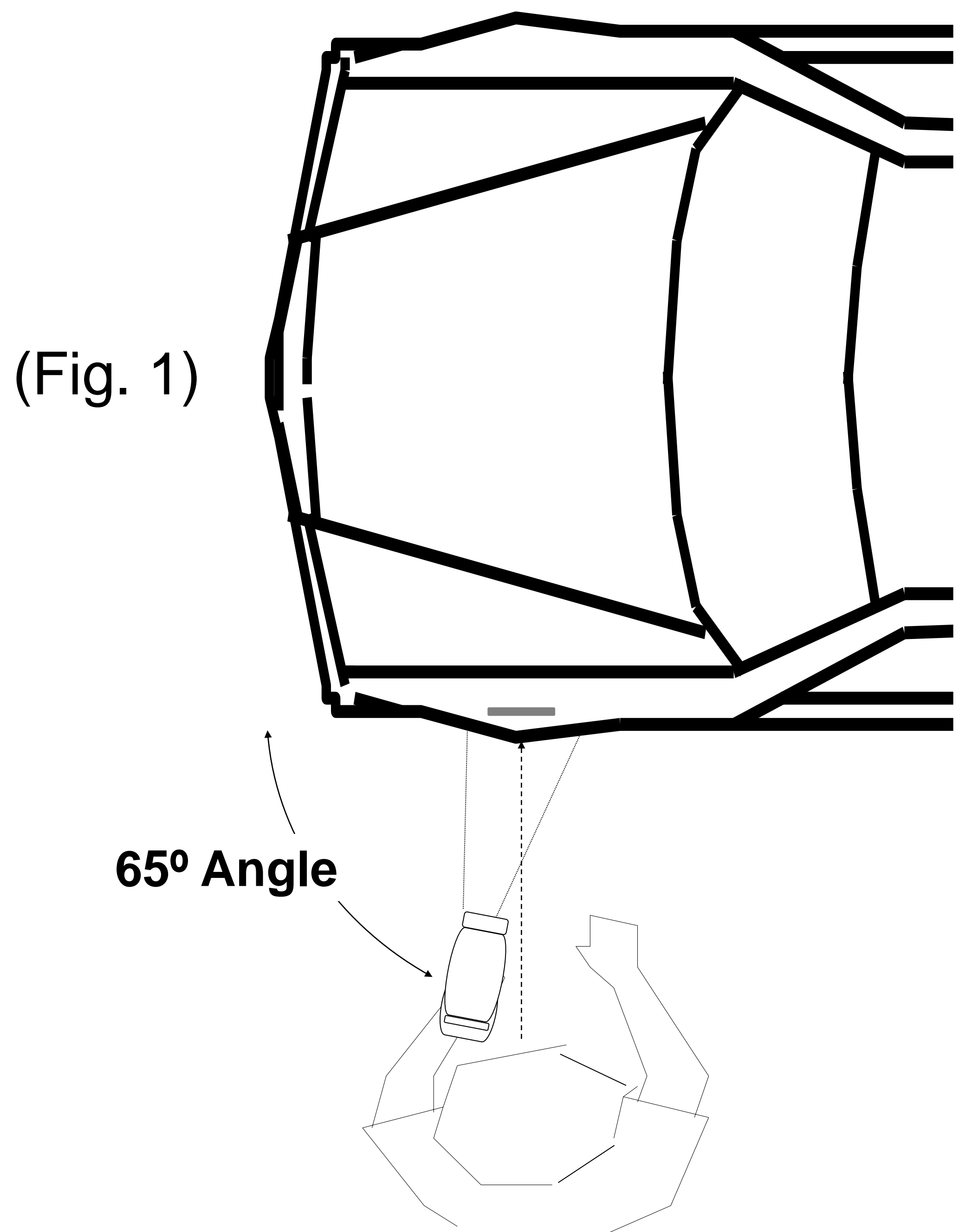

Observation and Assessment of Sprayout

Flip / Flop description technique

1. 3M Sun Gun should be at a 25° angle to the car and close to the technicians left ear. (Fig. 1)
2. The technicians eyes should be at a 12° - 15° angle to the car and approximately 12"- 18" away. (Fig. 1)
3. When viewing the variant or spray out swatch, the technician should be at eye level focusing primarily on the center and bottom of the panel. (Fig. 2)

